

Technical sheet

M 50-4

Masted Forklift Trucks



	Technical characteristics	Metric
1.1	Manufacturer	Manitou
1.2	Model	M 50-4
1.3	Type of traction	Diesel
1.4	Type of operation	Seated
1.5	Q - Rated capacity	5000 kg
1.6	c - Center of gravity of load	600 mm
1.8	x - Distance from the load bearing surface to the centre of the front axle	773 mm
1.9	y - Wheelbase	2120 mm
Weight		
2.1	Weight of truck in working order	8325 kg
2.2	Laden weight on front/rear axle	11520 kg / 1805 kg
2.3	Unladen weight on front/rear axle	3285 kg / 5040 kg
Wheels		
3.1	Tyre equipment: bandage (V), PPS (SE), inflatable tyre (L)	L
3.2	Size of front wheels	18-22.5 MPT06
3.5	Number of front wheels (x)	2x / 2x
3.6	b10 - Front track	1.62 mm
3.7	b11 - Rear track	1.74 mm
Dimensions		
4.1	α / β - Front/Rear mast angle	15 ° / 15 °
4.2	h1 - Height (mast lowered)	2910 mm
4.4	h3 - Lift height (Duplex mast)	3700 mm
4.5	h4 - Height of extended mast	4800 mm
4.7	h6 - Height of driver protection (cab)	2910 mm
4.8	h7 - Height of seat	1400 mm
4.12	h10 - Height of towing coupling	760 mm
4.19	l1 - Total length	4948 mm
4.20	l2 - Length to fork heel	3748 mm
4.21	b1 - Overall width - Singe/twinned wheels	2080 mm / -
4.22	e / s / l - Fork dimensions	1200 X 150 X 60
4.24	b3 - Width of fork clamp	1670 mm
4.31	m1 - Ground clearance under mast	295 mm
4.33	Ast - Aisle width for 1000 x 1200 pallet widthwise	6812 mm
4.34	Ast - Aisle width for 800 x 1200 pallet lengthwise	6812 mm
4.35	Wa - Turning radius	4640 mm
4.36	b13 - Inner turning radius	1650 mm
Performances		
5.1	Speed of travel laden / unladen	10 km/h / 24 km/h
5.2	Lifting speed laden / unladen	0.40 m/s / 0.40 m/s
5.3	Lowering speed laden / unladen	0.40 m/s / 0.30 m/s
5.5	Nominal pulling force laden / unladen	10200 daN / -
5.10	Service brake	Oil-Immersed Multi-Discs on Front & Rear Axles
Engine		
7.1	Engine manufacturer / Type	Perkins - 854F-E34T WF / Stage 3B
7.2	Useful power	55 kW
7.3	Rated speed	2200 rpm
7.4	Number of pistons / Capacity	4 / 3400 cm ³
7.5	Fuel consumption according to VDI cycle	6.90 l/h
Miscellaneous		
8.2	Working hydraulic pressure for attachments	230 bar
8.3	Oil flow rate for attachments	97 l/min
8.4	Measured/guaranteed mean noise level at the ear of the operator	76 dB(A)

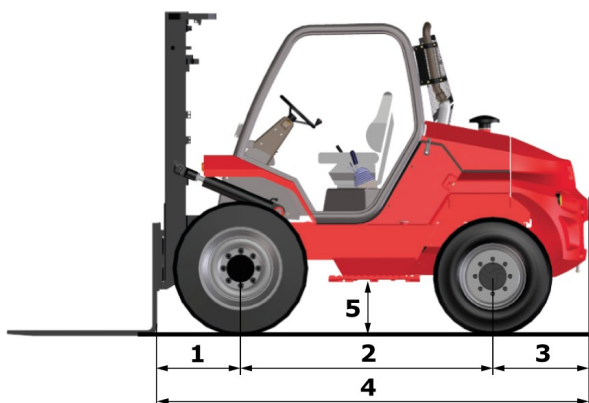

Characteristics of masts and residual capacities

Duplex Total Visibility		FVD 30	FVD 33	FVD 35	FVD 37	FVD 40	FVD 45	FVD 50
Lift height	mm	3060	3360	3560	3760	4060	4560	5060
Height (mast lowered)	mm	2560	2710	2810	2910	3060	3305	3560
Free lift	mm	0	0	0	0	0	0	0
Height of extended mast	mm	4115	4415	4615	4815	5115	5615	6115
Residual Capacity without attachment (Industrial load chart)	kg	5000	5000	5000	5000	5000	4500	4000
Residual Capacity with integrated side shift (Industrial load chart)	kg	4700	4700	4700	4700	4700	4000	3600

Triplex Free Lift		FLT 37	FLT 40	FLT 43	FLT 45	FLT 47	FLT 50	FLT 55	FLT 60
Lift height	mm	3760	4060	4360	4560	4760	5060	5560	6060
Height (mast lowered)	mm	2310	2410	2510	2585	2645	2760	2910	3085
Free lift	mm	1265	1365	1465	1540	1600	1715	1865	2040
Height of extended mast	mm	4805	5105	5405	5605	5806	6105	6605	7105
Residual Capacity without attachment (Industrial load chart)	kg	5000	5000	4500	4000	3700	3300	2400	2000
Residual Capacity with integrated side shift (Industrial load chart)	kg	4500	4500	4000	3600	3300	3000	2150	1800



Siège Social
430 rue de l'Aubinière - 44150 Ancenis Cedex - France
Tel: +33(0)2 40 09 10 11 - Fax: +33 (0)2 40 09 10 97
www.manitou.com



This brochure describes versions and configuration options for Manitou products which may be fitted with different equipment. The equipment described in this brochure may be standard, optional or not available depending on version. Manitou reserves the right to change the specifications shown and described at any time and without prior warning. The manufacturer is not liable for the specifications given. For more information, contact your Manitou dealer. Non-contractual document. Product descriptions may differ from actual products. List of specifications is not comprehensive. The logos and visual identity of the company are the property of Manitou and may not be used without authorisation. All rights reserved. The photos and diagrams contained in this brochure are provided for information only.

MANITOU BF SA - Limited company with board of directors - Share capital: 39,547,824 euros - 857 802 508 RCS Nantes